

The 208 ToolBox buildnotes for batch 8 - 9 - 10

Assembly

Some resistors values are printed on the rear of the PCB, mount them on this side will ease selection or modification without having to take the whole thing apart. You want to mount the 120k connected to the "CV" pad of the "pulse-CV" switch to the rear as well and be able to adapt its value.

The given values for the CV inputs are the ones I use, you might prefer other values to best fit your needs.

The "MO hi" and "MO lo" adjust the MO transpose range are labeled 120k on the batch 8 PCB but value can be dropped up to 20k to allow a wider transpose range.

The "LED" resistors value depends on the LED type, with some 220 ohms is enough while others will still make you blind even with 3k.

Silkscreen error on **batch 9 PCB : the cap near the TL072's pin 4 is 10nF, not 100nF.**

Do not socket the TL072, the socket might upset the adjacent slider's alignment with the panel.

Make sure the TL072 doesn't touch the slider.

On some batch 9 PCBs a track is missing between contact rear 7 of the edge connector and a resistor, check continuity and bridge if needed with a wire as shown in red.

Barely solder the central leg of the switches in a way it stays in place and leave the other 2 unsoldered. This will ease the panel mounting. Solder the switches properly when in their final position.

Place the LEDs in their emplacement before final mounting but do not solder them. When the panel is mounted, push the LEDs into their hole and solder them, so they'll fit easily.

The pots in the BOM are Alpha 9mm with black plastic shaft. The PCB accepts the Alpha 9mm with metal shaft as well. To mount these the panel holes need to be redrilled in 7mm because of the nut's thread, or you want to use 15mm standoffs instead of 12mm, but this might make the 208's top switches less comfortable to use. Rogan knobs can be mounted to the black plastic shaft.

Mount a mini slide switch to the pulse / CV pads to select if the socket above the switch is a EG pulse input or delay time CV input. If a dedicated EG pulse input is preferred as an option, bridge the CV pad to the central pad.

The +15V, 0V and -15V pads are meant to power extra circuit built on the perfboard. Those shouldn't be connected to anything else.

208c / Easel Command

The built-in gate to trigger converter of the envelope generator pulse input doesn't work for the 208c / Easel Command and should be bypassed by a 120k resistor soldered between the mini slide switch's "pulse" terminal and the "self" switch's common (central terminal). The CD4093 located next to the perfboard can be ommitted.

Options

Before to start customize your ToolBox, if you're not familiar with the 208's original program cards using resistors, please read the Meta-Programming section of Allen Strange's Music Easel manual. This will help you understand how the ToolBox works and adapt the options to your own needs thanks to a good selection of the features and resistor values.

The front panel has 3 small holes on the top left, are guides to drill holes of the needed diameter and host a socket, a switch, a pot, a LED etc... aligned with the other holes of the panel and PCB.

To add a new CV or pulse input or output, connect the socket to the edge connector via a resistor.

For sequencer pulse in use a 18k resistor, for pulser in 390k, for a switch CV : 200K, for a pulse out : 120k, for a CV in : 120k, but feel free to experiment. There's virtually no risk to damage anything by swapping resistors.

To shortly trig the pulser pulse input, the unused half (pins 7 to 13) of the CD4093 next to the perfboard can be used between the inut and the 390k resistor.

The CD4093 pins are already interconnected on the PCB.

This doesn't work for the 208c / Easel Command.

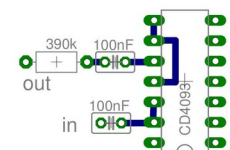
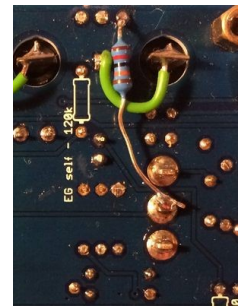
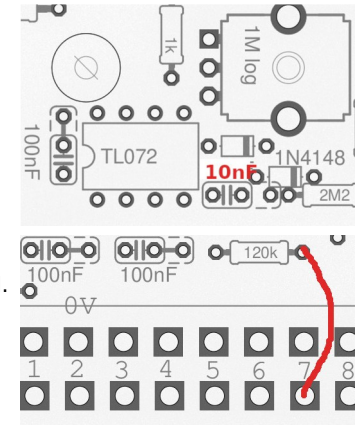

You can also do connections directly to the rear of the edge connector and use the "to prog" sockets of the 208 panel as inputs. These inputs already have resistance, thus you want to slightly lower the value of the resistor you'll use. Here again there's no fixed rule, feel free to experiment and find what best suits your needs. Connect a 180k resistor between front pin 26 and rear pin 28 will give CV input to the LPG2 routing switch on the preamp "to prog" socket.

Connect a 120k between rear pins 16 and 23 is a pulse in to fire the pulser on the inverter "to prog" socket.

The PCB's perfboard has a place for a pot in the top left corner and can host small circuits such as this square wave oscillator, it's dead simple (no CV in) and is a great addition to feed the 208's preamp and balanced modulador and as a modulation or clock source. A 47k resistor gives an audio range of about 25Hz to 1500Hz, a 10M in series gives LFO range with slowest period of about 5 seconds. These frequencies may vary depending on the 741, you want to test various values and find the ranges you like. Thanks to a slide switch mounted near the PCB's edge, audio or LFO range can be switched easily. On batch 9 a perboard is available behind the sliders too.

Here are some pics of a built circuit

http://www.portabellabz.be/images/toolbox/square_osc.zip

Noise generator, slew limiter, quantizer, summer, logic... are possible as well, many schematics are available on the interweb.

A more elaborated oscillator circuit based on a NE566 is available on http://www.portabellabz.be/images/toolbox/ne566_oscillator.zip

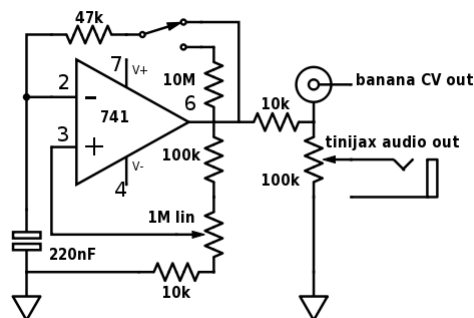

The "to card" sockets can be used as inputs to a circuit.

The "from card" can be used as an output, with a 100k resistor in series,

The "mixer in" round pad connected to a 120k resistor in the mixer section is meant to add a 3rd input to the mixer and can be connected to a "to prog" socket of the 208 panel, or to a banana socket mounted in the options section in the top left corner. An optional attenuator or attenuverter pot can be added in the perfboard section.

To interconnect the 208 with eurorack modules via the Toolbox, it's good to attenuate the minijack outputs.

The 208's output voltages can go up to +15V but eurorack works with lower voltages and you don't want to exceed the +/-12V of the power rails, this might damage the module.

The standard gate and trigger signals in eurorack are +5V. Your eurorack system might thus not appreciate a +15V gate or trigger signal, especially digital modules with a 5V power rail.

A 100k trimmer in series with the minijack will help calibrate the output to the convenient voltage with an oscilloscope.

Thank you and have fun !

Latest update : February 6th 2024

I assume no liability for personal injury or damage to equipment or loss of use caused directly or indirectly by the use of the 208 ToolBox. Although this build is quite simple it should only be performed by those experienced in electronics, if in doubt, don't do it.

I'm happy to help in some cases but I don't offer free support. These PCBs are for the ones able to debug their own builds.

Please understand remote troubleshooting of a wrong build might be very difficult and time consuming. In case of unsolvable problem, contact me to have your unit shipped to me and fixed at cost.

As I'm constantly improving my designs, some changes might occur without notice and can't be subject to complaint. I'm happy to answer any question, feel free to ask before ordering.

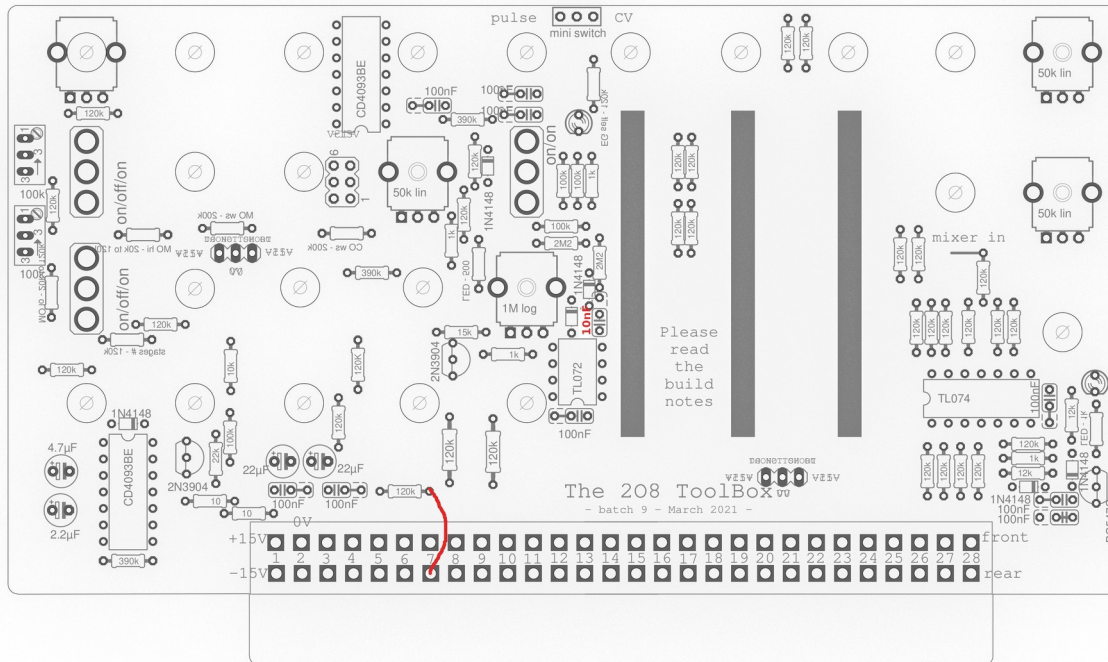

Edge connector pinout

Front	Rear
1 : +15V	1 : -15V
2 : 0V	2 : NC
3 : NC	3 : NC (+5V on BEMI 208)
4 : NC	4 : NC
5 : NC	5 : NC
6 : NC	6 : NC
7 : seq step 1 out	7 : seq step 2 out
8 : seq step 3 out	8 : random 1 out
9 : seq step 4 out	9 : pulser period CV in
10 : seq step 5 out	10 : MO index CV in
11 : seq steps #	11 : MO freq CV in
12 : seq pulse setting	12 : sequencer pulse in
13 : seq CV setting	13 : CO pitch CV in
14 : random pulse in	14 : keyboard pulse out
15 : seq CV out	15 : keyboard key CV out
16 : random 2 out	16 : pulser pulse in
17 : EG pulse in	17 : timbre CV in
18 : pulser pulse out	18 : attack CV in
19 : duration CV in	19 : keyboard pressure CV out
20 : pulser out	20 : EG CV out
21 : decay CV in	21 : sequencer pulse out
22 : LPG1 level CV in	22 : MO modulation switch CV in
23 : MO ws CV in	23 : inverter "to prog"
24 : CO & MO key	24 : CO waveshape pot CV in
25 : LPG2 level CV in	25 : CO waveshape switch CV in
26 : preamp "to prog"	26 : LPG1 mode switch CV in
27 : LPG2 mode switch CV in	27 : offset (+13.5V)
28 : inverter "from prog"	28 : signal routing switch CV