

The BOB expander build notes batch 2

Please check you well have the build notes matching your PCB revision. Happy building !

Assembly

The rear and front panels come linked as a single board, bend it will break the 3 small tabs, you can equalize the edge with a file or a Dremel after breaking the tabs.

Some resistors values are printed on the rear of the PCB, mount them on this side will ease selection or modification without having to take the whole thing apart.

Do not socket the TL071/TL081/LM741, the IC socket corner would upset the banana socket placement. Or snip the socket's corner.

The 100k trimmer is optional and will reduce the pulser trig out voltage for use with external devices needing a trigger signal lower than +15V (eurorack uses +5V gates and triggers). You want to bypass it if not needed and connect the banana socket directly to the trimmer's pin 1. The cable can be replaced with a 1N4148 diode (line to the socket) to protect the output from reverse patching.

The +15V, 0V and -15V pads are meant to power extra circuit built on the perfboard. Those shouldn't be connected to anything else.

208c / Easel Command

The built-in gate to trigger converter of the pulser pulse input doesn't work for the 208c / Easel Command and should be bypassed by a 120k resistor soldered between the pulser in banana socket terminal and 390k resistor lead as shown on the pic. The 390k resistor can be omitted.

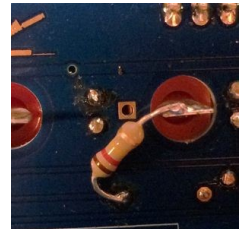

Options

The front panel has 3 small holes to the right, are guides to drill holes of the needed diameter and host a socket, a switch, a pot, a LED etc... aligned with the other holes of the panel and PCB.

To add a new CV or pulse input or output, connect the socket to the edge connector via a resistor.

A good value for a pulse in is 390k, for a switch CV : 200K, for a pulse out : 120k, for a CV in : 120k, but feel free to experiment. There's virtually no risk to damage anything by swapping resistors.

You can also do connections directly to the rear of the edge connector and use the "to prog" sockets of the 208 panel as inputs. These inputs already have resistance, thus you want to slightly lower the value of the resistor you'll use. Here again there's no fixed rule, feel free to experiment and find what best suits your needs.

Connect a 180k resistor between front pin 26 and rear pin 28 will give CV input to the LPG2 routing switch on the preamp "to prog" socket.

Connect a 120k between rear pins 16 and 23 is a pulse in to fire the pulser on the inverter "to prog" socket.

The PCB's perfboard has a place for a pot in the top left corner and can host small circuits such as this square wave oscillator, it's dead simple (no CV in) and is a great addition to feed the 208's preamp and balanced modulator and as a modulation or clock source. A 47k resistor gives an audio range of about 25Hz to 1500Hz, a 4.7M in series gives LFO range with slowest period of about 5 seconds. These

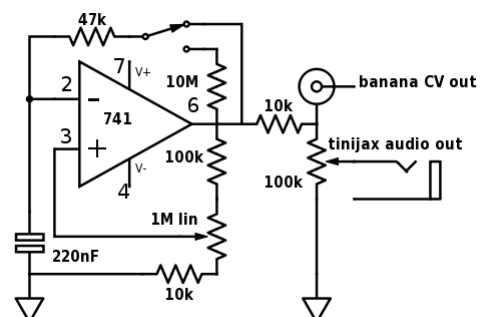

frequencies may vary depending on the 741, you want to test various values and find the ranges you like. Thanks to a slide switch mounted near the PCB's edge, audio or LFO range can be switched easily.

A more elaborated oscillator circuit based on a NE566 is available on

http://www.portabellabz.be/images/toolbox/ne566_oscillator.zip

Noise generator, slew limiter, quantizer, summer, logic... are possible as well, many schematics are available on the interweb.

The "to card" sockets can be used as inputs to a circuit, the "from card" proved not working for this purpose.

To interconnect the 208 with eurorack modules via the Toolbox, it's good to attenuate the minijack outputs.

The 208's output voltages can go up to +15V but eurorack works with lower voltages and you don't want to exceed the +/-12V of the power rails, this might damage the module.

The standard gate and trigger signals in eurorack are +5V. Your eurorack system might thus not appreciate a +15V gate or trigger signal, especially digital modules with a 5V power rail.

A 100k trimmer in series with the minijack will help calibrate the output to the convenient voltage with an oscilloscope.

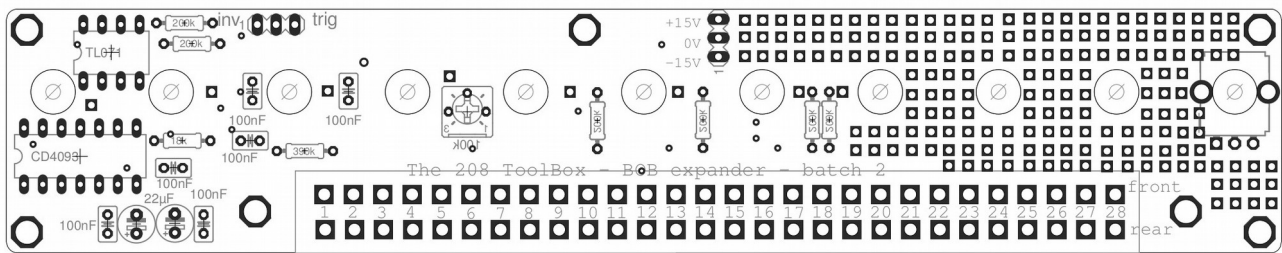

BOM for the basic features only, think to add the parts for your options to the list ;)

ICs

- 1 x TL071 / TL081 / 741
- 1 x CD4093BE

Capacitors

- 6 x 100nF ceramic 2,54mm footprint
- 2 x 22µF electrolytic 2,54mm footprint

Resistors

- 1 x 100k trimmer - Mouser 858-25PR100KLF (optional)
- 1 x 390k
- 6 x 200k
- 1 x 18k

Hardware

- 4 x black banana socket - Mouser 530-108-0903-1
- 2 x orange banana socket - Mouser 530-108-0906-1
- 2 x red banana socket - Mouser 530-108-0902-1
- 1 x mini slide switch - <http://www.taydaelectronics.com/electromechanical/switches-key-pad/slide-switch/mini-slide-switch-1p2t-through-hole-0-2a-24vdc.html>
- 6 x 12mm F/F M3 standoff
- 5 x 5mm M/F M3 standoff
- 11 x 4mm M3 screw
- 2 x 12mm M3 screw + 1 nut
- 56 way PC mount edge connector - LW-N28A2G on ebay

Have fun and happy building !

Edge connector pinout

Front	Rear
1 : +15V	1 : -15V
2 : 0V	2 : NC
3 : NC	3 : NC (+5V on BEMI 208)
4 : NC	4 : NC
5 : NC	5 : NC
6 : NC	6 : NC
7 : seq step 1 out	7 : seq step 2 out
8 : seq step 3 out	8 : random 1 out
9 : seq step 4 out	9 : pulser period CV in
10 : seq step 5 out	10 : MO index CV in
11 : seq steps #	11 : MO freq CV in
12 : seq pulse setting	12 : sequencer pulse in
13 : seq CV setting	13 : CO pitch CV in
14 : random pulse in	14 : keyboard pulse out
15 : seq CV out	15 : keyboard key CV out
16 : random 2 out	16 : pulser pulse in
17 : EG pulse in	17 : timbre CV in
18 : pulser pulse out	18 : attack CV in
19 : duration CV in	19 : keyboard pressure CV out
20 : pulser out	20 : EG CV out
21 : decay CV in	21 : sequencer pulse out
22 : LPG1 level CV in	22 : MO modulation switch CV in
23 : MO ws CV in	23 : inverter "to prog"
24 : CO & MO key	24 : CO waveshape pot CV in
25 : LPG2 level CV in	25 : CO waveshape switch CV in
26 : preamp "to prog"	26 : LPG1 mode switch CV in
27 : LPG2 mode switch CV in	27 : offset (+13.5V)
28 : inverter "from prog"	28 : signal routing switch CV

I assume no liability for personal injury or damage to equipment or loss of use caused directly or indirectly by the use of the 208 ToolBox and BOB expander. Although this build is quite simple it should only be performed by those experienced in electronics, if in doubt, don't do it.

I'm happy to help in some cases but I don't offer free support. These PCBs are for the ones able to debug their own builds.

Please understand remote troubleshooting of a wrong build might be very difficult and time consuming. In case of unsolvable problem, contact me to have your unit shipped to me and fixed at cost.

As I'm constantly improving my designs, some changes might occur without notice and can't be subject to complaint.

I'm happy to answer any question, feel free to ask before ordering.

November 26th 2017